

SPECIFICATION FOR APPROVAL

承 認 書

Product	MAGNETIC BUZZER(RoHS Grade)
Part No.	SN12 05GP
Customer Approval	

Approved By	Checked By	Made By
钱万进	易申	曹小丽

1. Specifications

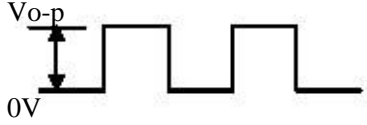
Items		Units	Specifications	Conditions
01	Rated Voltage	V _{o-p}	5	
02	Operating Voltage	V _{o-p}	3.0 ~ 8.0	
03	Consumption Current	mA (Max)	Min 40	Applying rated voltage, rated frequency Square wave, 1/2 duty subject to standard state.
			Peak 120	
04	Direct Current Resistance	Ohm	47±5	
05	Sound Output	dBA (min)	85	Distance at 10cm, applying rated voltage, rated frequency square wave, 1/2 duty subject to standard state.
06	Rated Frequency	Hz	2400	
07	Operating Temp.	°C	-20 ~ +70	
08	Storage Temp.	°C	-30 ~ +80	
09	Weight	Gram	2	

2. Measuring Method

2-1. Test Condition

STANDARD

Temperature : 15 ~ 35°C

Relative humidity : 25% ~ 85%,

Atmospheric pressure : 860mbar to 1060mbar.

JUDGEMENT

Temperature : 20±3°C

Relative humidity : 60% ~ 70%,

Atmospheric pressure : 860mbar to 1060mbar

2-2. Standard Drive Circuit:

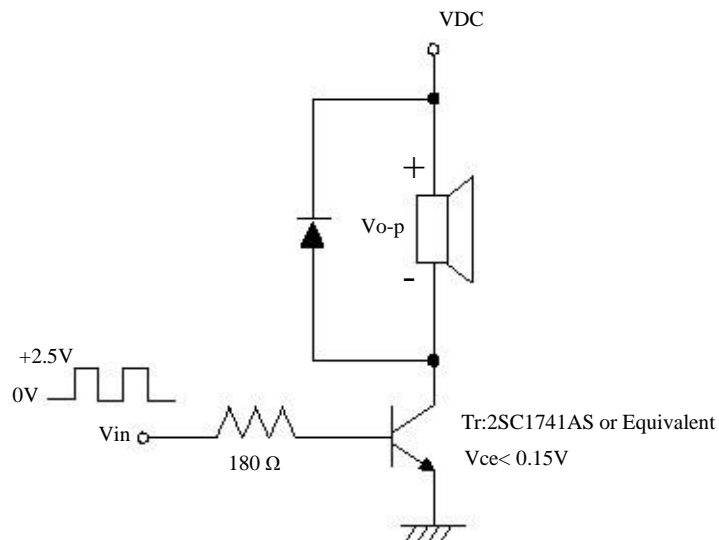

2-3. Standard Test Fixture

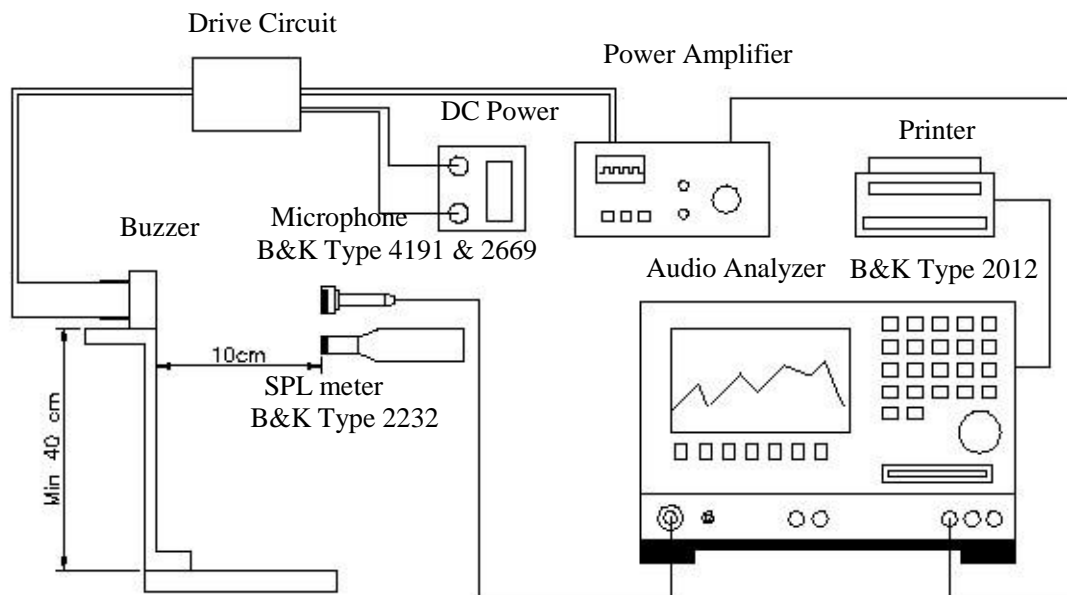

2-4. Frequency Response Curve

X: 3.3714kHz Y: 93.12dB SA: Live Curve SQR T. RMS

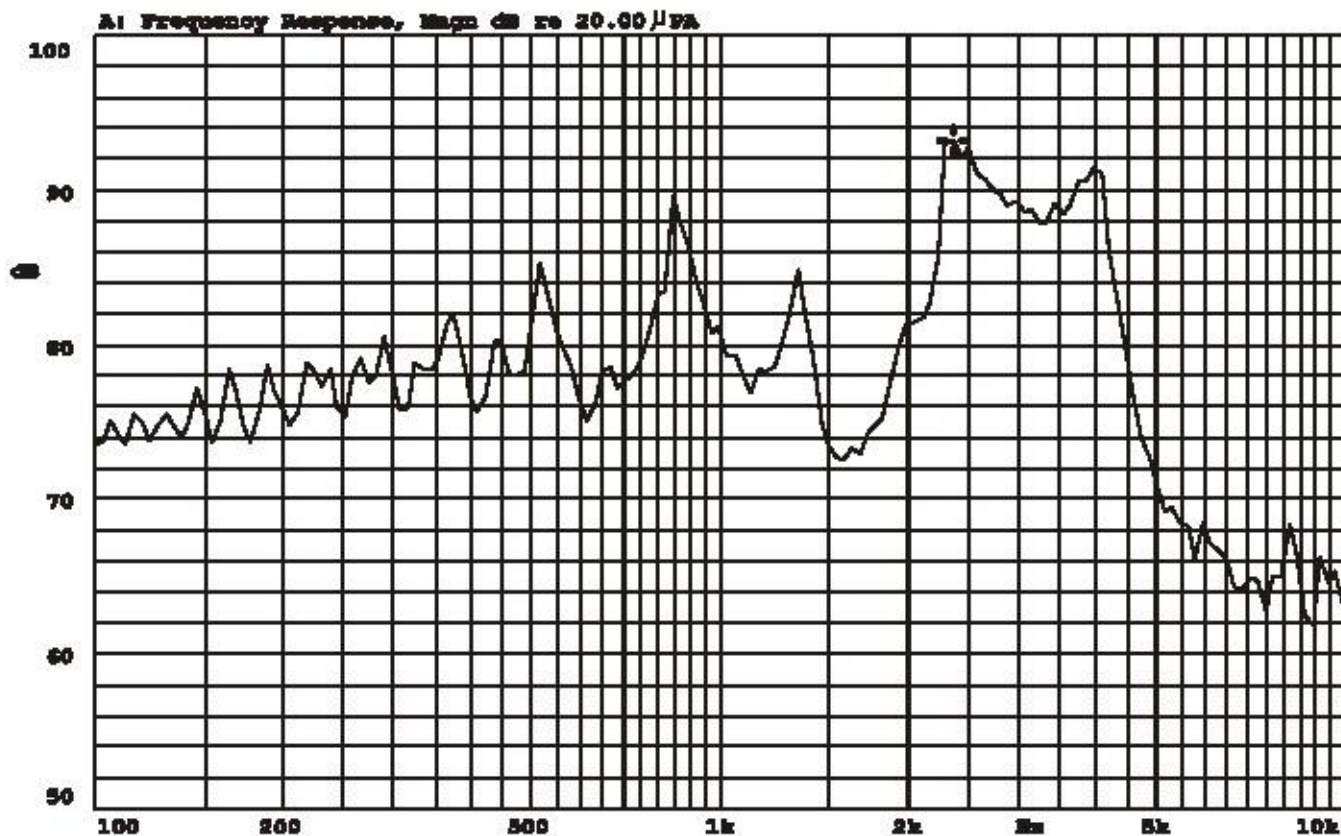

Model: 800



※ WAVE SOLDER AND WASH ALLOWED.

■ DIMENSION

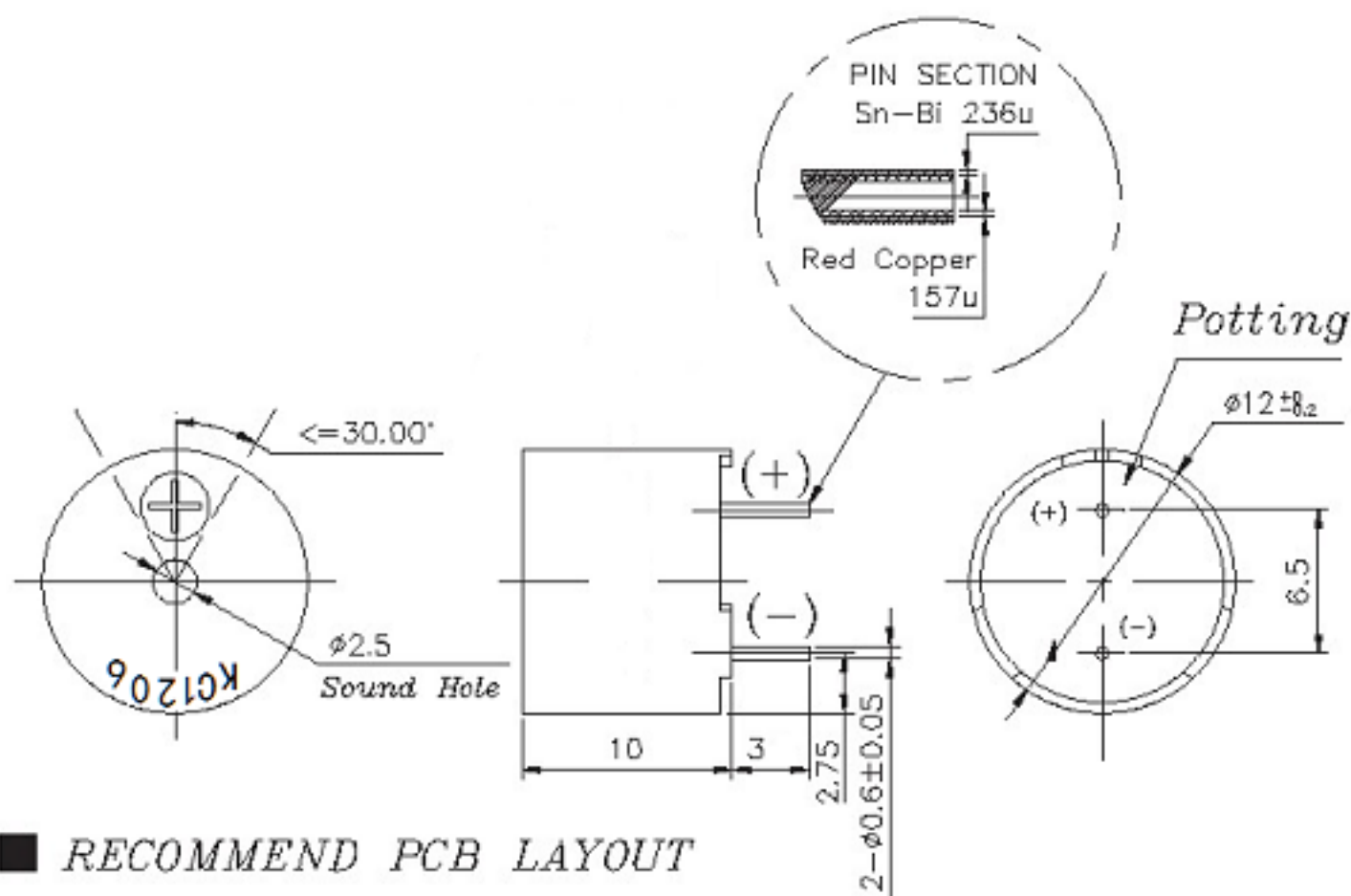

■ RECOMMEND PCB LAYOUT

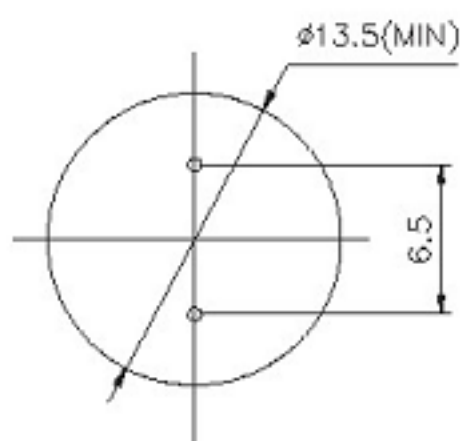

4. RELIABILITY TEST

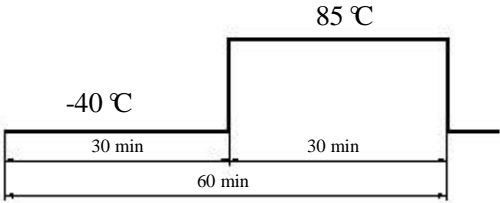
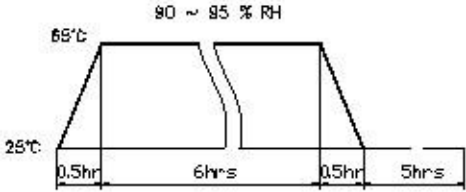
Item	Test conditions	Evaluation standard
01 High temp.Storage life	The part shall be capable of withstanding a storage Temperature of 85°C for 96 hours.	After the test the part shall meet specifications without Any degradation in appearance and performance except S.P.L S.P.L shall be 77dB or more.
02 Low temp.Storage life	The part shall be capable of withstanding a storage Temperature of -40°C for 96 hours.	
03 Temp. cycle	The part shall be subjected 10 cycles. One cycle shall consist of; 	
04 Temp./Humidity cycle	The part shall be subjected 10 cycles. One cycle shall be 12 hours and consist of; 	
05 Operating life	Rated Voltage,Frequency applied. 1. Ordinary temperature The part shall be subjected to 1000 hours at room temperature (25 ±10°C) 1. High temperature The part shall be subjected to 500 hours at 75°C 2. Low temperature The part shall be subjected to 500 hours at -30°C	
06 Vibration	The part shall be subjected to a vibration cycle of 10Hz to 55Hz to 10Hz in a period of 1 minute. Total peak amplitude shall be 1.52mm (9.3G). The vibration test shall consist of 2 hours per plane in each three mutually perpendicular planes for a total time of 6 hours.	